

Filmax

MODEL FP2108P PORTABLE FILTRATION SYSTEM

WATER & PARTICULATE FILTRATION SYSTEM FOR SHOP OR SUBSTATION MAINTENANCE

APPLICATIONS

**Transformer Oil • Quench Oil Hydraulic Oil
Water Glycols • Turbine Oil • Gear Oil
Cutting Oil • Lube Oil**

SPECIFICATIONS

- 3/4 HP TEFC Heavy Duty Motor with Thermal Overload Protection.
- 8 GPM Positive Displacement Gear Pump with Internal Relief Valve.
- Two (2) Polyurethane Powder Baked F-1000 Element Housings.
- Wired 110 Volt, 1 Phase with all electrical components mounted in a NEMA 4 enclosure.
- 0-100 PSI Glycerin Filled Gauge for monitoring system pressure.
- Automatic High/Low Pressure Shutdown System for unattended operation.
- All Brass Fittings and Stainless Steel Tubing plumbed for independent operation.
- Two (2) 15 ft.-1/2" inlet and outlet hydraulic hoses with hose ends.
- Thirty (30) feet of Heavy Duty 12/3 Power Cable.
- Manufactured with 3-way ball valve for Fluid Transfer System and to allow for adding makeup oil.
- Suction-Wye Strainer to protect pump from large debris.
- Heavy Duty 10" pneumatic tires.
- Filtration Capacity of 6 GPM and Fluid Transfer Capacity of 8 GPM.





MODEL FP2108P

Water and Particulate Filtration System

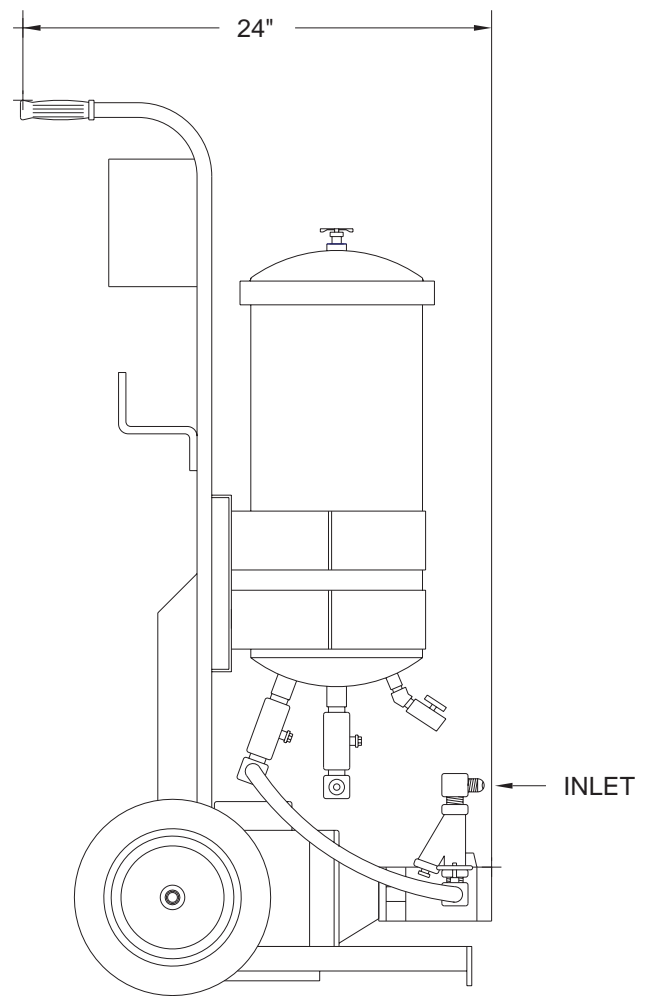
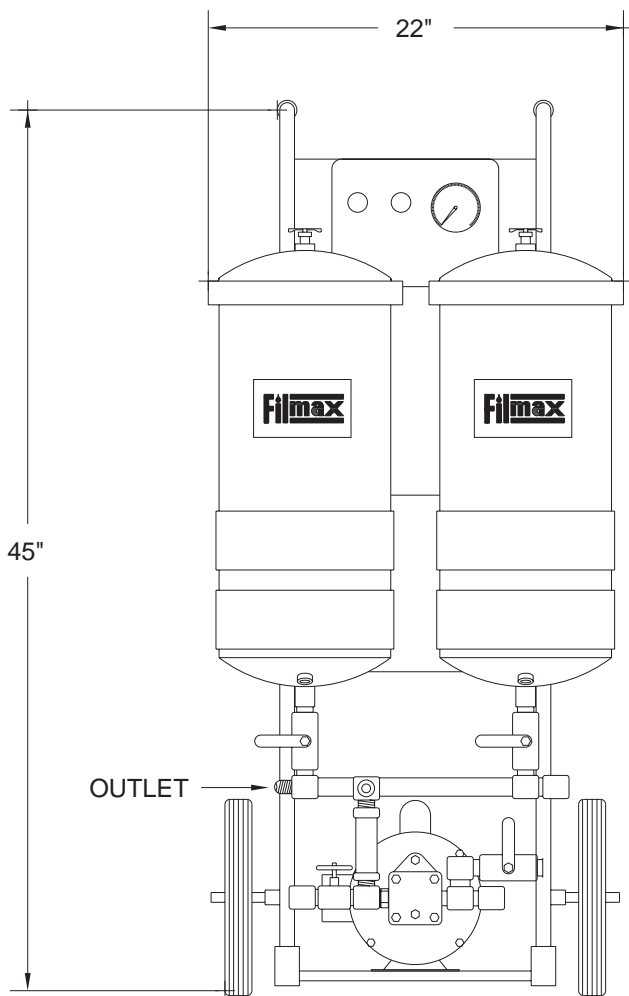

Filmax is the industry leader in the application of filtration technology for the removal of water and particulate contamination in insulating oil. Filmax holds the most recent patents for specific advancements in oil filtration technology, which allows the company to manufacture the finest oil filtration equipment in the industry. We at Filmax are committed and dedicated to providing the highest standard of customer service and technical support in the industry.